

Environmental Product Declaration according to ISO 14025 and EN 15804

Product specific values for the calculation of the environmental impact of a building

Rigips® Bauplatte RB
Rigips® Die Blaue RB
Rigips® Die Leichte RB
Rigips® Ausbauplatte
Rigicell® 10
Rigips® Die Weiße RB
Rigips® 4PRO
Rigips® GK-Form
Rigips® Climafit®

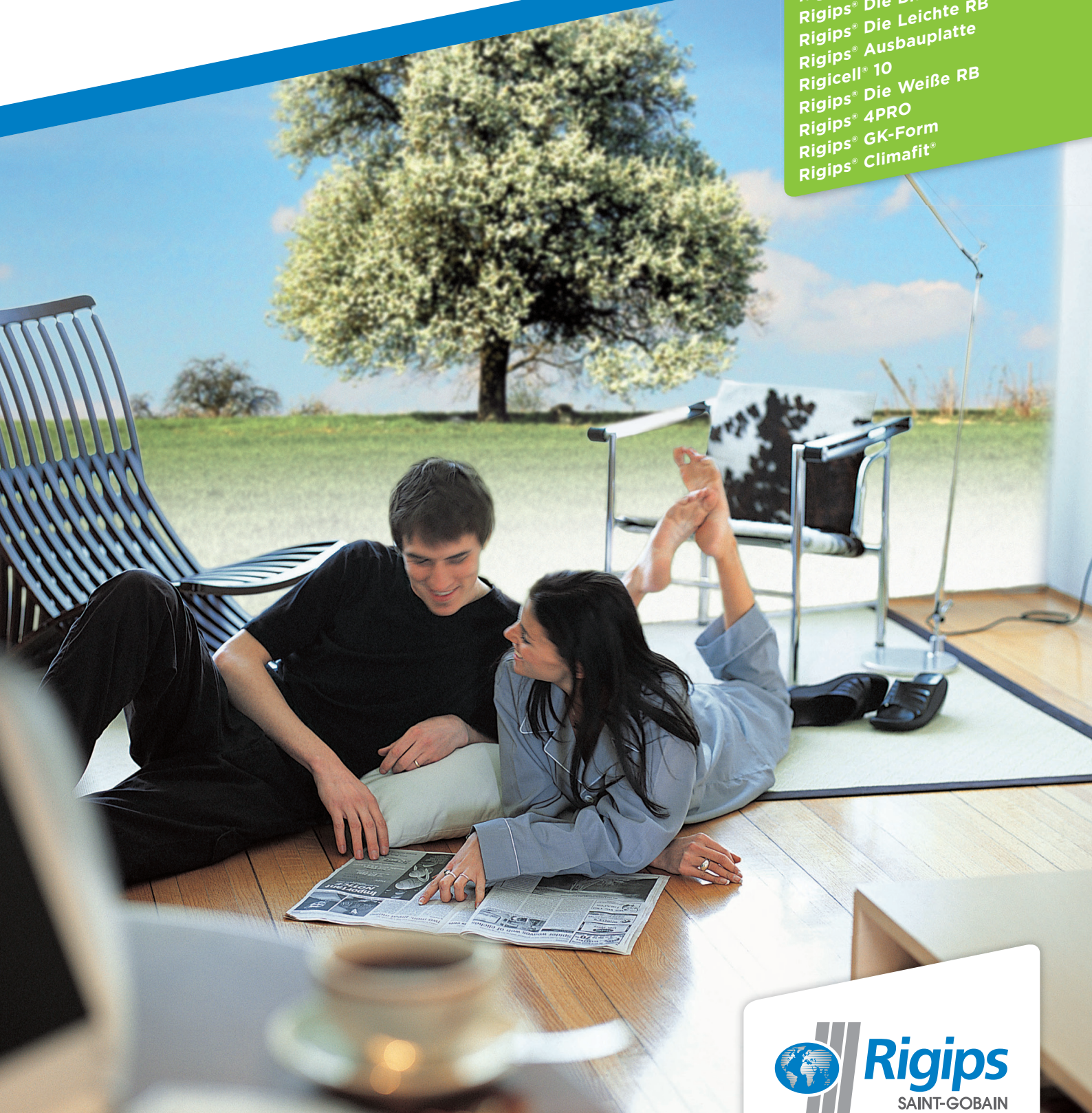

The Original. For space to live.

ENVIRONMENTAL PRODUCT DECLARATION

as per /ISO 14025/ und /EN 15804/

Owner of the Declaration	Bundesverband der Gipsindustrie e.V.
Publisher	Institut Bauen und Umwelt e.V. (IBU)
Program holder	Institut Bauen und Umwelt e.V. (IBU)
Declaration number	EPD-BVG-SGR-20140075-IAG1-EN
Issue date	17.10.2017
Valid to	19.08.2020

Rigips Plasterboards Saint-Gobain Rigips GmbH

www.ibu-epd.com / <https://epd-online.com>

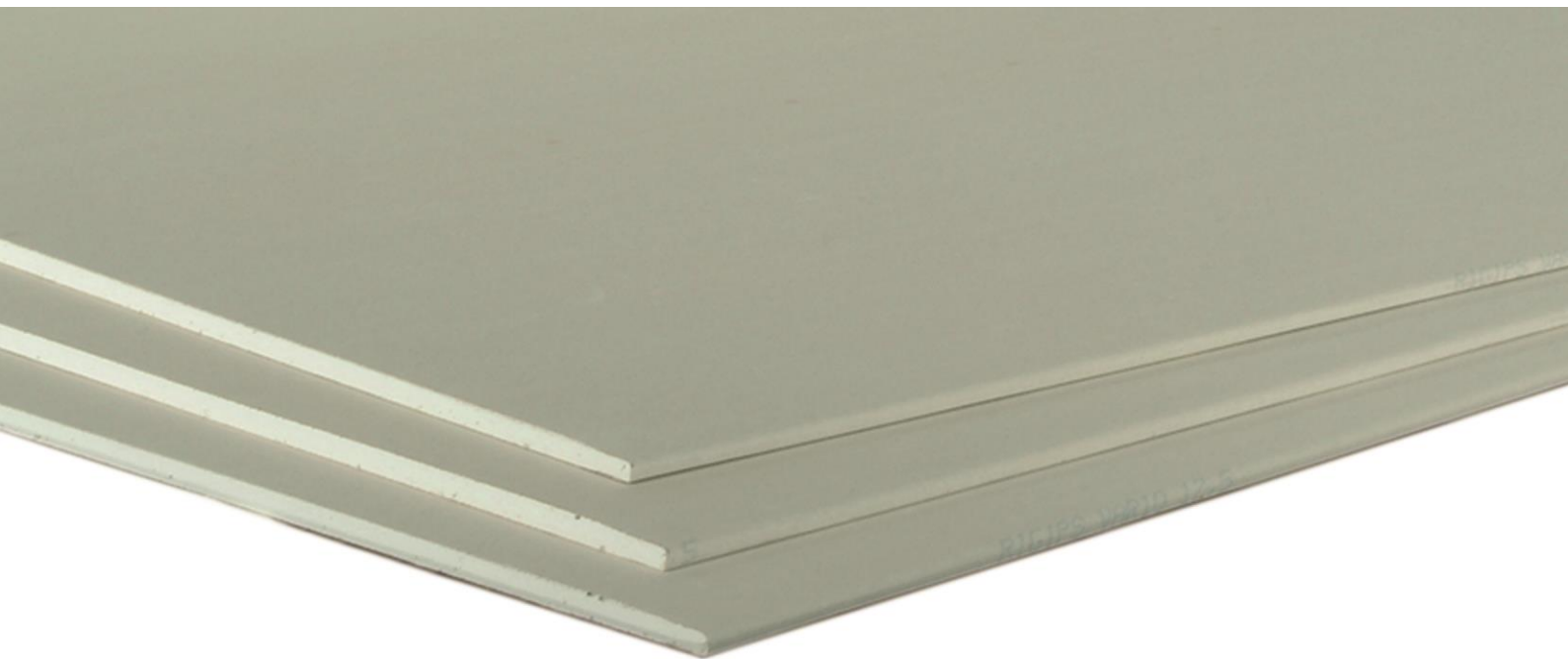

1. General Information

Bundesverband der Gipsindustrie e.V.

Program holder

IBU - Institut Bauen und Umwelt e.V.
Panoramastr. 1
10178 Berlin
Deutschland

Declaration number

EPD-BVG-SGR-20140075-IAG1-EN

This Declaration is based on the Product

Category Rules:

Plasterboard, 07.2014
(PCR tested and approved by the SVR)

Issue date

15.11.2017

Valid to

19.08.2020



Prof. Dr.-Ing. Horst J. Bossenmayer
(President of Institut Bauen und Umwelt e.V.)



Dr.-Ing. Burkhard Lehmann
(Managing Director IBU)

GYP SUM PLASTERBOARD IN ACCORDANCE WITH DIN EN 520 AND DIN 18180

Owner of the Declaration

Bundesverband der Gipsindustrie e.V.
Kochstraße 6-7
10969 Berlin

Declared product / Declared unit

Gypsum plasterboard in accordance with /DIN EN 520/
and /DIN 18180/
1m² (10 kg)

Scope:

The EPD applies for all member companies of the Bundesverband der Gipsindustrie e.V. in accordance with the current list of members on www.gips.de and for products manufactured in Germany. The LCA considers specific information supplied by the manufacturers and suppliers of components exclusively for the cradle-to-gate production stage. This document is translated from the German Environmental Product Declaration into English. It is based on the German original version EPD-BVG-20140075-IAG1-DE. The verifier has no influence on the quality of the translation. The owner of the declaration shall be liable for the underlying information and evidence; the IBU shall not be liable with respect to manufacturer information, life cycle assessment data and evidences.

Verification

The CEN Norm /EN 15804/ serves as the core PCR

Independent verification of the declaration
according to /ISO 14025/

internally externally



Dr.-Ing. Wolfram Trinius,
(Independent verifier appointed by SVR)

2. Product

2.1 Product description

The declaration refers to gypsum plasterboard with a surface weight of 10 kg/m².

2.2 Application

Gypsum plasterboards are directly pasted to the subsurface as dry plaster, as panelling for partition and ceiling cladding, mounting partitions and suspended ceilings made of wood or galvanised metal and for manufacturing prefabricated components such as those screwed or nailed in the prefabricated building industry.

Applications of gypsum plasterboards as metal stud systems with single or double panelling in dry interior construction are outlined in the Environmental System Declaration ESD-BVG-2013111-D (IBU ESD-BVG-2013111-D).

They can be used in buildings for public, private or commercial applications.

2.3 Technical Data

Technical information is available in the information supplied by the manufacturers. Due to continuous updating of technical standards or approvals, such information is not listed within the framework of the Environmental Product Declaration.

Details on essential requirements can be taken from the CE mark and/or Declaration of Performance (Construction Products Regulation).

If necessary, more information is available in the standards, the Gypsum Data Book issued by the Bundesverband der Gipsindustrie e.V. /Gypsum Data Book/ and information supplied by the manufacturer.

2.4 Placing on the market / Application rules

Regulation (EU) No. 305/2011 dated 9 March 2011 applies for placing on the market within the European Union /EFTA.

The products require a Declaration of Performance taking consideration of DIN EN 520:2009-12: Gypsum plasterboards – Definitions, requirements and test methods; German version EN 520:2004+A1:2009 and CE marking.

Use is governed by the respective national guidelines; /DIN 18180/ is the national application standard in Germany. DIN 18181 applies for processing the gypsum plasterboards.

As a general rule, DIN 4103-1 applies for non-load-bearing interior partitions, DIN 4103-4 applies for wooden stud systems and DIN 18183-1 applies for metal stud systems; DIN 18168-1 and DIN 18168-2 must be observed for suspended ceilings and ceiling panelling.

2.5 Delivery status

Gypsum plasterboards can be supplied in various formats considering various thicknesses and individual requirements.

A distinction is made between the following types:

Gypsum plasterboard Type A in accordance with /DIN EN 520/, Type GKB in accordance with /DIN 18180/: gypsum plasterboard referred to as building panel in accordance with DIN, for all standard applications

Gypsum plasterboard Type D (gypsum plasterboard with defined density) in accordance with /DIN EN 520/: gypsum plasterboard with a defined density of at least 800 kg/m³ for ensuring improved performance in certain applications

Gypsum plasterboard Type I (gypsum plasterboard with increased surface strength) in accordance with

/DIN EN 520/: gypsum plasterboard designated for applications with increased surface hardness requirements

Gypsum plasterboard Type P in accordance with /DIN EN 520/, Type GKP in accordance with /DIN 18180/: boards whose visible side are intended for the application of gypsum plaster or glued bonding with other materials such as gypsum plasterboards or board-shaped substances

Gypsum plasterboard Type R (gypsum plasterboard with increased strength) in accordance with /DIN EN 520/: these gypsum plasterboards are designated for applications requiring increased longitudinal and horizontal breaking strength.

Impregnated gypsum plasterboard and fire-resistant gypsum plasterboard (e.g. Types E, F, H) are not a component of this EPD.

2.6 Base materials / Ancillary materials

Gypsum plasterboards are manufactured in a continuous process from stucco and additives for the gypsum core (incl. starch and foaming agent) as well as high-quality, multi-pressed cardboard on large conveyor systems.

They do not contain any substances > 0.1% by weight which are included in the "Candidate List of Substances of Very High Concern" /ECHA 2013/.

2.7 Manufacture

The manufacturing process comprises the steps depicted in Figure 1.

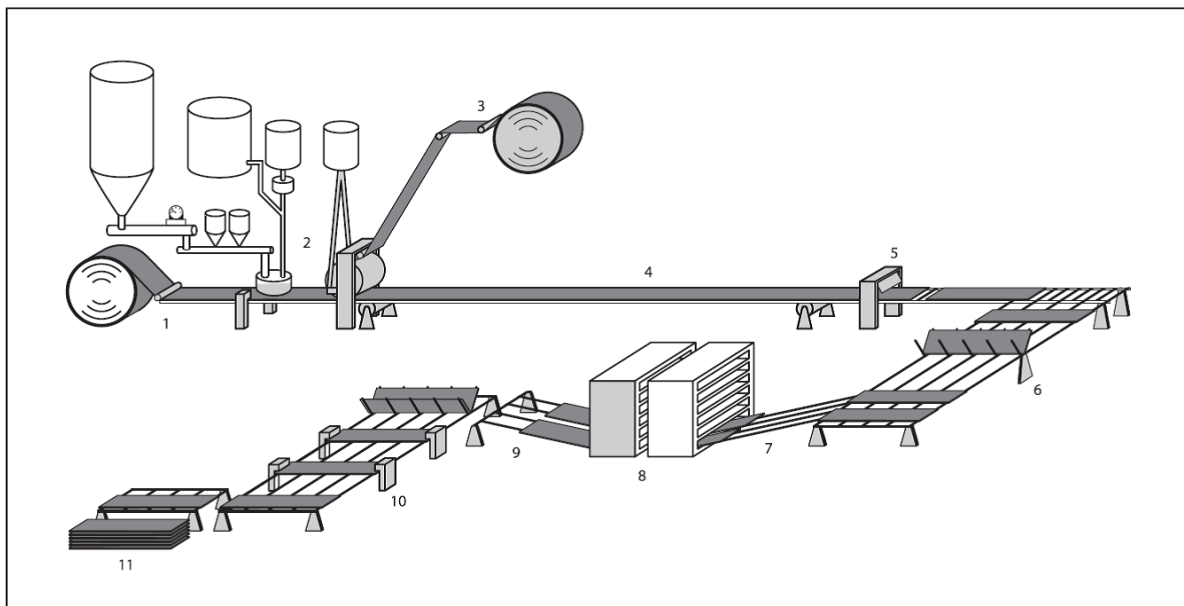

Fig. 1: Gypsum plasterboard manufacturing process in accordance with the /Gypsum Data Book/

- Cardboard is fed in facing downwards forming the visible side of the panel and incised to form the edges (1).
- Addition of gypsum slurry which is spread in the forming station as the cardboard is fed in from above (2 – 3).

- Setting section with shears for cutting (4 – 5)
- Turning table with input in a multi-level drier (6 – 8)
- Panel discharge with trimming of transverse edges and bundling (9 – 11)

The manufacturing companies implemented a Quality Management System and are certified to /DIN EN ISO 9001/.

2.8 Environment and health during manufacturing

Gypsum plasterboards are manufactured in plants permitted by emission laws in accordance with the specifications of the Federal Immission Control Act. The plants implement an Energy Management System in accordance with /DIN EN ISO 50001/. As of an aggregated rated thermal input of > 20 MW, gypsum plants are subject to emissions trading.

2.9 Product processing/Installation

The products are processed in accordance with the relevant information leaflets issued by the Bundesverband der Gipsindustrie e.V. and the manufacturers.

During the cutting, sawing or grinding processes for gypsum products, the occupational exposure limit value of 6 mg/m³ alveolar dust (A-dust) must be observed for calcium sulphate as a time-weighted average; in accordance with /TRGS 900/ "Occupational Exposure Limit Values" (issued in January 2006, last amended and supplemented by GMBI 2012, p. 11 [No. 1]). If necessary, dust-reducing measures or organisational measures must be taken which are oriented towards the /TRGS 559/ "Mineral Dust" (issued in February 2010) and the exposure categories outlined therein.

2.10 Packaging

Gypsum plasterboards are stored on pallets and delivered without packaging. The wooden pallets are available as reusable or disposable pallets.

2.11 Condition of use

The useful life of the gypsum plasterboards for interior applications reviewed here generally complies with the overall useful life of the building. They are not subject to any exterior exposure.

2.12 Environment and health during use

During the use phase, no hazardous substances are emitted which exceed the limit values of the /AgBB/ test scheme.

Gypsum plasterboards are tested by the Institut für Bauphysik /Scherer 2010/.

The test result indicates that the gypsum plasterboards are not associated with any adverse effects on the interior.

2.13 Reference service life

Reference Service Lives depend on the respective applications.

In accordance with the BBSR "Nutzungsdauern von Bauteilen für Lebenszyklusanalysen nach dem Bewertungssystem Nachhaltiges Bauen (BNB)" (Useful lives of components for LCAs in accordance with the Sustainable Building assessment system) table, last revised 03.11.2011, this is >50 years for partitions as per code number 342.411 "Non-supporting interior partitions – Stud systems".

There are no influences on ageing when the recognised rules of technology are applied.

2.14 Extraordinary effects

Fire

Gypsum plasterboards offer outstanding fire protection with regard to their low density. This is due to the fact that the gypsum core contains approx. 20% water of crystallisation which evaporates when exposed to fire, thereby consuming energy by means of conversion. The temperature on the side facing away from the fire remains constant at approx. 110 °C over a longer period of time depending on the board thickness. The resulting dehydrated gypsum layer offers increased thermal insulation.

In accordance with Annex B of /DIN EN 520/, gypsum plasterboards are usually classified as A2-s1, d0 in terms of their fire performance. This classification to /DIN EN 13501-1/ means:

A2 = non-flammable, s1 = no smoke, d0 = no flaming droplets/particles.

Other classifications are depicted in the following table:

Gypsum plasterboard	Nominal board thickness (mm)	Gypsum core		Surface density of cardboard ¹⁾ (G) (g/m ²)	Sub-surface	Class ²⁾ (excl. floors)
		Density (M) (kg/m ³)	Fire classification			
According to DIN EN 520 (excl. perforated boards)	≥ 6.5 < 9.5	≥ 800	A1	≤ 220 > 200 ≤ 320	Each wood-based product with a density ≥ 400 kg/m ³ or each product min. A2-s1, d0	A2-s1, d0 B2-s1, d0
	≥ 9.5	≥ 600		≤ 220 > 220 ≤ 320	Each wood-based product with a density ≥ 400 kg/m ³ or each product min. class A2-s1, d0 or each insulation material min. class E-d2 fastened/mounted in accordance with method 1	A2-s1, d0 B2-s1, d0

¹⁾ Calculated as per DIN EN ISO 536 and with a max. content of 5% organic additives

²⁾ Classes as in Table 1 of the Annex to Commission Decision 200/147/EC

Water

Unless expressly designated by the manufacturer, all gypsum products must be protected from permanent humidity.

A leaflet is available from the Bundesverband der Gipsindustrie e.V. on restoration of components made of gypsum after flood damage (Flooding Leaflet).

Mechanical destruction

As a general rule, mechanical damage can be offset using jointing compound due to the ease of repair associated with the gypsum plasterboards and without any adverse effects on function.

Gypsum plasterboards can easily be replaced with new boards in the event of more extensive damage. No environmental consequences are to be anticipated in the event of unforeseen mechanical destruction.

2.15 Re-use phase

Re-use

The gypsum plasterboards can not be re-used for the same application without undergoing some change. For the remaining re-uses/disposals, segregation of building materials on the building site is recommended.

Further use

Gypsum plasterboards which are as good as new (e.g. cuttings) can be used after crushing and possibly separating the cardboard and coatings in agreement with the customer as recultivation material in mining areas, for recovery on landfills, as soil conditioner, fertiliser components or acceleration agents for cement, considering any official specifications.

Recycling

After treatment in special recycling plants for gypsum waste, recycled gypsum can be added to the manufacturing process for new boards following crushing and separation from the cardboard. Alternatively, the recycled gypsum can be used in the areas outlined for further use.

These recycling plants for gypsum waste also ensure that any screws or nails are removed by a magnetic separator.

Cardboard removed in these plants can be used as a secondary fuel or added to paper recycling; separated metals are recycled as scrap.

2.16 Disposal

Disposal in accordance with the waste code:

17 08 02 Gypsum-based construction materials other than those mentioned in 17 08 01

Gypsum-based construction materials adhere to the disposal conditions from landfill class 1 of the Landfill Ordinance in the case of landfilling.

2.17 Further information

www.gips.de

3. LCA: Calculation rules

3.1 Declared Unit

Deklarierte Einheit

Name	Value	Unit
Declared unit	1	m ²
Conversion factor to 1 kg	0.1	-

3.2 System boundary

The EPD refers to the production phase in accordance with /DIN EN 15804/, i.e. it comprises the manufacturing steps from the cradle to the factory gate.

Modules A1-A3 include the production of raw materials and transport thereof, the provision of energy and the manufacturing processes required for the production of all components for the gypsum plasterboard product.

3.3 Estimates and assumptions

Assumptions regarding transportation expenses were made for all materials required and for disposal.

3.4 Cut-off criteria

All components for manufacturing the gypsum plasterboards as well as all electricity and water required were considered. Accordingly, material and energy flows with a share of less than 1 per cent were also considered. It can be assumed that the processes neglected would have contributed less than 5% to the impact categories under review.

3.5 Background data

The "GaBi 5" software system for comprehensive analysis developed by PE INTERNATIONAL AG was

used for modelling the production of all components /GaBi 5 2012/.

The Life Cycle Assessment was modelled for Germany as a reference area. Consequently, apart from the production processes under these framework conditions, the upstream stages of relevance for Germany such as the provision of electricity or energy were also used. The electricity mix for Germany 2008 is used.

3.6 Data quality

All background data sets of relevance were taken from the GaBi 5 software data base.

3.7 Period under review

The data used by PE INTERNATIONAL AG complies with the current level of knowledge at the time of modelling the LCA in early 2013.

3.8 Allocation

Allocations were used in the background data for modelling the requisite components, e.g. for the provision of electricity. An allocation was avoided for the provision of FGD gypsum which is sometimes used for the production of calcium sulphate beta hemihydrate.

3.9 Comparability

Basically, a comparison or an evaluation of EPD data is only possible if all the data sets to be compared were created according to /EN 15804/ and the building context, respectively the product-specific characteristics of performance, are taken into account.

4. LCA: Scenarios and additional technical information

Technical information on the application forms the basis for developing specific scenarios within the context of a building evaluation.

Such scenarios for gypsum plasterboards are already available, e.g. for single- or double-layer metal stud frames with gypsum plasterboards (IBU ESD-BVG-2013111-D).

On account of the great number of possible applications, no scenarios are developed within the framework of this cradle-to-gate declaration; instead, reference is made to the Environmental System Declarations available on gypsum plasterboards.

5. LCA: Results

DESCRIPTION OF THE SYSTEM BOUNDARY (X = INCLUDED IN LCA; MND = MODULE NOT DECLARED)

PRODUCT STAGE			CONSTRUCTION PROCESS STAGE		USE STAGE							END OF LIFE STAGE				BENEFITS AND LOADS BEYOND THE SYSTEM BOUNDARIES
Raw material supply	Transport	Manufacturing	Transport from the gate to the site	Assembly	Use	Maintenance	Repair	Replacement	Refurbishment	Operational energy use	Operational water use	De-construction demolition	Transport	Waste processing	Disposal	Reuse-Recovery-Recycling-potential
A1	A2	A3	A4	A5	B1	B2	B3	B4	B5	B6	B7	C1	C2	C3	C4	D
X	X	X	MND	MND	MND	MND	MNR	MNR	MNR	MND	MND	MND	MND	MND	MND	MND

RESULTS OF THE LCA - ENVIRONMENTAL IMPACT: 1 m² = 10 kg Gipsplatte

Parameter	Unit	A1-A3
Global warming potential	[kg CO ₂ -Eq.]	2.09
Depletion potential of the stratospheric ozone layer	[kg CFC11-Eq.]	2.23E-10
Acidification potential of land and water	[kg SO ₂ -Eq.]	3.24E-3
Eutrophication potential	[kg (PO ₄) ³⁻ -Eq.]	7.96E-4
Formation potential of tropospheric ozone photochemical oxidants	[kg ethene-Eq.]	2.96E-4
Abiotic depletion potential for non-fossil resources	[kg Sb-Eq.]	1.65E-4
Abiotic depletion potential for fossil resources	[MJ]	32.21

RESULTS OF THE LCA - RESOURCE USE: 1 m² = 10 kg Gipsplatte

Parameter	Unit	A1-A3
Renewable primary energy as energy carrier	[MJ]	1.75
Renewable primary energy resources as material utilization	[MJ]	0.00
Total use of renewable primary energy resources	[MJ]	1.75
Non-renewable primary energy as energy carrier	[MJ]	32.21
Non-renewable primary energy as material utilization	[MJ]	0.00
Total use of non-renewable primary energy resources	[MJ]	32.21
Use of secondary material	[kg]	5.61
Use of renewable secondary fuels	[MJ]	0.00
Use of non-renewable secondary fuels	[MJ]	0.00
Use of net fresh water	[m ³]	0.01

RESULTS OF THE LCA – OUTPUT FLOWS AND WASTE CATEGORIES:

1 m² = 10 kg Gipsplatte

Parameter	Unit	A1-A3
Hazardous waste disposed	[kg]	0.00
Non-hazardous waste disposed	[kg]	0.51
Radioactive waste disposed	[kg]	0.00
Components for re-use	[kg]	IND
Materials for recycling	[kg]	IND
Materials for energy recovery	[kg]	IND
Exported electrical energy	[MJ]	IND
Exported thermal energy	[MJ]	IND

6. LCA: Interpretation

In calculating the LCA, a generic national raw material mix for gypsum is applied for the upstream chain in order to comply with the various levels of availability in the individual plants and the interchangeability and/or combination possibilities offered by raw gypsum. Gypsum can be procured as a raw material from nature or as a by-product from desulphurisation of coal-fired power stations (FGD gypsum). While all material and energy flows are considered for natural gypsum, the cut-off limit for FGD gypsum is represented by the expenses associated with the manufacture of FGD gypsum following desulphurisation (e.g. electricity consumption by the belt filter but not the use of limestone in the flue gas scrubber or the disposal of FGD waste water). Delivery to the gypsum plant is initially followed by the manufacture of calcium sulphate beta hemi-hydrate

(stucco) through combustion of the raw gypsum (calcination) below 180 °C. This stucco is then combined with water and additives and applied between the cardboard sheets. This process is followed by thermal removal of the excess moisture in a drier.

Production significantly dominates the LCA impact categories due to the calcination of the raw gypsum associated with the consumption of fossil energy sources and drying the boards; these two sub-processes are responsible for approximately 60% of the GWP.

There is no scarcity of the resources used, i.e. gypsum, cardboard made from waste paper and the additives used depending on the board type. More than 90% of the ADPE is dominated by the use of natural gypsum for which the sulphur content of the

earth's crust is applied as a criterion for calculating the Sb equivalent. As the LCA has been recorded from the

cradle to the factory gate, no credits are considered for possible recycling of gypsum at the end of life.

7. Requisite evidence

7.1 Leaching (sulphate + heavy metals)

On analysis according to the Landfilling Ordinance, the product displays the sulphate concentration in the saturation range which is typical for gypsum (approx. 1500 mg/l), resulting in disposal options only from landfill class I upwards.

Gypsum is classified as a listed substance in Water Hazard Class 1 (slightly hazardous for water). Heavy metal content is significantly below the corresponding criteria for landfill class I.

Proper disposal in accordance with the parameters which can depend on use, sorting depth during deconstruction, collection (separately or together with other construction waste) and treatment, and must be determined by the responsible waste producer.

7.2 Radioactivity

The product can be used without restriction with overall dose contributions of significantly lower than 0.3 mSv/a, determined on the basis of the index calculation to RP 112 and the radon concentration (BfS report).

7.3 VOC emissions

The requirements in accordance with the AgBB test scheme, version 2008, are satisfied with regard to all existing test items /Scherer 2010/:

TVOC $3 \leq 10$ mg/m³

Carcinogens 3 EU cat. 1 and 2 ≤ 0.01 mg/m³

TVOC 28 < 1.0 mg/m³

SVOC28 ≤ 0.1 mg/m³

Carcinogens 28 EU cat. 1 and 2 ≤ 0.001 mg/m³

Total VOC 28 excl. LCI ≤ 0.1 mg/m³

Total VOC incl. LCI $R = \sum Ci/LC_i < 1$

8. References

Institut Bauen und Umwelt

Institut Bauen und Umwelt e.V., Berlin(pub.):
Generation of Environmental Product Declarations (EPDs);

General principles

for the EPD range of Institut Bauen und Umwelt e.V. (IBU), 2013/04
www.bau-umwelt.de

ISO 14025

DIN EN ISO 14025:2011-10: Environmental labels and declarations — Type III environmental declarations — Principles and procedures

EN 15804

EN 15804:2012-04+A1 2013: Sustainability of construction works — Environmental Product Declarations — Core rules for the product category of construction products

/Construction Products Regulation/
Directive (EU) No. 305/2011 of the European Parliament and Council dated 9 March 2011 establishing harmonised conditions for marketing building products and replacing Council Guideline 89/106/EEC; ABI. EU L88/5 dated 4.4.2011

/BBSR Reference Service Life/
BBSR table "Service lives of components for LCA in accordance with BNB"
"Sustainable Building Information Portal" by the Federal Ministry of Transport, Building and Urban Affairs: <http://www.nachhaltigesbauen.de/baustoff-und-gebaeuedaten/nutzungsdauern-von-bauteilen.html>, last revised: 03.11.2011

/BfS report/
Natural radioactivity in construction materials and the ensuing radiation exposure

Field of radiation protection and environment
K. Gehrcke, B. Hoffmann, U. Schkade, V. Schmidt, K. Wichterey; urn:nbn:de:0221-201210099810
Federal Office for Radiation Protection, Salzgitter, November 2012
http://doris.bfs.de/jspui/bitstream/urn:nbn:de:0221-201210099810/3/BfS_2012_SW_14_12.pdf

/DIN EN 4103-1/
DIN 4103-1:2014-03
Title (German): Internal non-load-bearing partitions – Part 1: Requirements and Requisite Evidence

/DIN EN 4103-4/
DIN 4103-4:1988-11
Title (German): Internal non-load-bearing partitions; Partitions with timber framing

/DIN EN 18168-1/
DIN 18168-1:2007-04
Title (German): Ceiling linings and suspended ceilings with gypsum plasterboards – Part 1: Requirements for construction

/DIN EN 18168-2/
DIN 18168-2:2008-05
Title (German): Ceiling linings and suspended ceilings with gypsum plasterboards – Part 2: Verification of the load-carrying capacity of metal sub-constructions and metal suspending rods

/DIN 18180/
DIN 18180:2013-12
Title (German): Gypsum plasterboards – Types and requirements

/DIN 18181/
DIN 18181:2008-10
Title (German): Gypsum plasterboards for building construction – Application

/DIN EN 18183-1/
DIN 18183-1:2009-05
Title (German): Partitions and wall linings with gypsum boards on metal framing – Part 1: Cladding with gypsum plasterboards

/DIN EN 520/
DIN EN 520:2009-12
Title (German): Gypsum plasterboards – Definitions, requirements and test methods; German version EN 520:2004+A1:2009

/DIN EN ISO 9001/
DIN EN ISO 9001:2008-12 (D/E/F)
Quality management systems – Requirements (ISO 9001:2008); trilingual version EN ISO 9001:2008

/DIN EN 13501-1/
DIN EN 13501-1:2010-01
Title (German): Classification of building products and types by fire performance – Part 1: Classification with the results of tests on Reaction to Fire by construction products; German version EN 13501-1:2007 + A1:2009

/DIN EN 15804/
DIN EN 15804/A1:2013-05
Title (German): Sustainability of construction works – Environmental product declarations – Core rules for the construction products product category; German version EN 15804:2012/FprA1:2013

/DIN EN ISO 50001/
DIN EN ISO 50001:2011-12
Environmental management systems – Requirements with guidance for use (ISO 50001:2011)

/ECHA 2013/
European Chemicals Agency (ECHA)
Candidate List of Substances of Very High Concern for Authorisation (published in accordance with Article 59(10) of the REACH Regulation)
<http://echa.europa.eu/de/candidate-list-table>, last revised: 20 June 2013

/GaBi 5 2012/

GaBi 5: Software and data base for comprehensive analysis, LBP, University of Stuttgart and PE International
GaBi 5 documentation
<http://documentation.gabi-software.com/>, (2012).

/Gypsum Data Book/
Gypsum Data Book
Pub.: Bundesverband der Gipsindustrie e. V., Kochstrasse 6–7, 10969 Berlin
Published on: www.gips.de (section: Publications / Books), last revised: May 2013

/IBU ESD-BVG-2013111-D/
Environmental System Declaration in accordance with ISO 14025 and EN 15804
Metal stud partitions with plasterboards/fibreboards
Declaration number ESD-BVG-2013111-D
Bundesverband der Gipsindustrie e.V.
Pub.: Institut Bauen und Umwelt (IBU), 14.01.2013

/Flooding Leaflet/
Removing damage caused by flooding to components made of gypsum or gypsum plaster
BVG Information Service No. 01
Published on: www.gips.de (section: Download, Publications, Information services), last revised: June 2013

/Scherer 2010/
Fraunhofer-Institut für Bauphysik IBP, Holzkirchen
Test report
Cross-sectional study on the emission potential of volatile organic compounds from gypsum components and gypsum products for interior applications (July 2010)
Published on: www.gips.de (section: Research association, Projects, 2010)

TRGS 900 "Occupational exposure limit values" (issued January 2006, last amended and supplemented GMBI 2012, p. 11 [No. 1])

TRGS 559 "Mineral dust" (issued February 2010)

**Publisher**

Institut Bauen und Umwelt e.V.
Panoramastr. 1
10178 Berlin
Germany

Tel +49 (0)30 3087748- 0
Fax +49 (0)30 3087748- 29
Mail info@bau-umwelt.com
Web www.bau-umwelt.com

**Programme holder**

Institut Bauen und Umwelt e.V.
Panoramastr 1
10178 Berlin
Germany

Tel +49 (0)30 - 3087748- 0
Fax +49 (0)30 – 3087748 - 29
Mail info@bau-umwelt.com
Web www.bau-umwelt.com

**PE INTERNATIONAL****Author of the Life Cycle Assessment**

PE INTERNATIONAL AG
Hauptstraße 111
70771 Leinfelden-Echterdingen
Germany

Tel +49 (0)711 34817-0
Fax +49 (0)711 341817-25
Mail info@pe-international.com
Web www.pe-international.com

**Owner of the Declaration**

Bundesverband der Gipsindustrie e.V.
Kochstraße 6-7
10969 Berlin
Germany

Tel +49 (0)30 31169822-0
Fax +49 (0)30 31169822-9
Mail info@gips.de
Web www.gips.de

Saint-Gobain Rigips GmbH

Headquarters
Schanzenstrasse 84
40549 Duesseldorf
Germany

Phone +49 (0) 211 5503-0
Fax +49 (0) 211 5503-208

info@rigips.de
rigips.de



Export Team

Saint-Gobain Rigips GmbH
Schanzenstrasse 84
40549 Duesseldorf
Germany

exportde@saint-gobain.com
rigips.de
rigitone.com

Further Information:



rigips.de

